

Model	Part Number	Strap Size		Coil Winding		Weight	
		inch	mm	Mill	Ribbon	lbs	kg
DPCL	CGXA585852	3/8-2	9.5-50.8	•	•	450	204

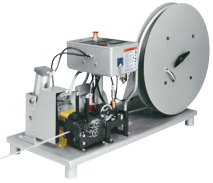

**DPCL**  
Cuts strapping automatically up to 100 ft. in length.

# Cutters



**Model CU-25** | Part No. 005740  
For strap removal or cutting strap to length. Replaceable blades. Cuts strap through 2" x 0.050" (50.8 mm x 1.27 mm).  
Shipping weight: 8 lbs. (3.6 kg)



**Model CU-25LH** | Part No. 0X-1528  
Extra long handle cutter. Replaceable blades. Cuts strap through 2" x 0.050" (50.8 mm x 1.27 mm).  
Shipping weight: 8 lbs. (3.6 kg)



**Model CU-30** | Part No. 005899  
Lightweight. One-hand operation. Cuts strap through 1-1/4" x 0.035" (31.8 mm x 0.89 mm).  
Shipping weight: 3 lbs. (1.35 kg)



**Model CY-30** | Part No. 426010  
Heavy-duty alloy steel. Cuts strap through 1-1/4" x 0.035" (31.8 mm x 0.89 mm).  
Shipping weight: 3 lbs. (1.35 kg)



**GripPack Cutter** | Part No. 800770  
For strap removal or cutting strap to length. Cuts through two straps up to 1-1/4" x 0.044" (31.8 mm x 1.12 mm).  
Shipping weight: 7.5 lbs. (3.4 kg)  
See page 11 for battery and charger - sold separately)

# Coil Lifters

Capable of lifting up to 125 lb. strap coils, the standard coil lifter is designed for easy dispenser loading, both vertically and horizontally. Accommodates both mill and ribbon wound steel strap coils as well as standard plastic coils.



**Portable model**  
Part No. 424700



**Stationary model**  
Part No. 425650

# Pneumatic Accessories

**For steel and plastic strapping**



Offered by Signode Parts and Service only. Available at [www.signodeparts.com](http://www.signodeparts.com).

## Pneumatic accessories



**Note:** Only use lightweight air tool oil in lubricator, such as Non-fluid Oil No. L0713-54 (Part No. 008556).

Check the air pressure at the tool with a separate air gauge to verify proper air pressure.



Standard air gauge. (Part No. 425238)



Quick-connect safety socket for standard air supply. (Part No. 429134)



Quick-connect plug for low standard air supply. (Part No. 020704)

## Filter-regulator-lubricator (FRL)

Assembly (Part No. 429141, with 1/2" I.D. hose) or (Part No. 429130, without hose) is needed with all pneumatic tools and equipment. Additional pneumatic accessories are available from Signode, such as those shown on right, to help provide optimum operation. Please contact your local Signode sales representative for more information on the proper fittings for your specific tool or equipment.



High air flow gauge. (Part No. 429127)



Quick-connect socket for high flow air supply. (Part No. 015294)



Quick-connect plug for high flow air supply. (Part No. 015293)

## Recommended Air Line Piping

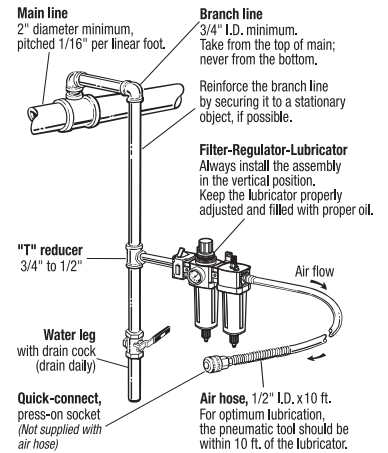

Bi-directional 360° swivel connector for increased operator control and maneuverability. (Part No. 426903)



Filter bushing (Part No. 024631) Screened bushing reduces air line particles from entering the tool.



# Accessories

## Steel and plastic edge protectors

For strapping up to 1-1/4" (31.8 mm) wide, Signode steel and plastic edge protectors cushion your product and allow straps to be tightly applied without causing damage. Plastic ribbed edge protectors are available in red, blue, white or yellow for color coding.

Steel



MF-11, MF-12

EG3A

Plastic



PL1

P41 Series

## Anchor plates

Used to secure ends of strap to car studs.

## Anti-skid plates

Anti-skid plates are simple, inexpensive devices that minimize product shifting in trailers or railcars.

Part No. 001999



Used beneath pallets or skids in trailers or railcars. For lighter loads. Diameter: 1-3/8" (34.9mm). Standard pack: 2500 pcs., 43 lbs. (19.5 kg).

## Steel and plastic edge protectors

Model	Part Number	Color	Composition	Maximum Strap Width		Edge Protector Dimensions						Standard Package	Package Weight	
						Length		Width		Thickness			lbs	kg
						inch	mm	inch	mm	inch	mm			
MF-11†	001261	Metallic	Steel	3/4	19.0	5/8	15.9	4	101.6	0.031	0.79	1,000	57	25.9
MF-12†	001263					5/8	15.9	4	101.6	0.048	1.22	1,000	57	25.9
7	001598	Metallic	Steel	1-1/4	31.8	2	50.8	2-3/4	69.9	0.030	0.76	500	47	21.3
EG3A	001260					2-1/2	63.5	3-1/8	79.4	0.031	0.79	150	31	14.1
PL1	085971	White	Plastic	3/4	19.0	1-1/4	31.8	2	50.8	0.062	1.58	2,000	23	10.4
P41 Series	041504	Red	Plastic	1-1/4	31.8	2	50.8	2-3/4	69.9	0.093	2.11-2.36	1,000	40	18.1
	041505	White												
	041506	Blue												
	041507	Yellow												

\*Galvanized † For use in automatic edge protector applicators



## Anchor plates

Model	Part Number	Strap Width		Plate Dimensions		Standard Pack	Shipping Weight	
		inch	mm	inch	mm		lbs	kg
—	001294B	1-1/4	31.8	4 x 2 x 1/8	101.6 x 50.8 x 3.18	200	51	23.2

# Battery-powered Tools

**SIGNODE®**

**For plastic strapping**

## Battery-Operated Friction-weld

The BXT2 combination tools apply polypropylene or polyester strapping, utilizing friction weld joint technology to join strap ends. Automatic weld function speeds up cycle time. The battery-operated BXT2 has a simple two-button process and ergonomic design to reduce operator fatigue.

Model	Part Number	Strap Type				Description	Applied Tension lbs.		Joint Type	Approx. Shipping Weight		# of batteries included
		Contrax		Tenax			lbs	N		lbs	kg	
		inch	mm	inch	mm							
BXT2-10	800570	3/8-1/2	9-13	3/8-1-2	9-15.9	Battery	275	1 223	Friction-weld	7.5	3.4	1
BXT2-16	428340	—	—	1/2-5/8	12.7-15.9	Battery	550	2 446	Friction-weld	8.6	3.9	2
BXT2-19	428350	—	—	5/8-3/4	15.9-19.0	Battery	880	3 914	Friction-weld	8.6	3.9	2
BXT2-25	2640315	—	—	1	25.4	Battery	1,460	6 494	Friction-weld	14.3	6.5	1
BXT2-32	2640325	—	—	1-1/4	32	Battery	1,460	6 494	Friction-weld	14.3	6.5	1



\*Battery and charger are included with tool

## Dispensers

Model	Part Number	Strap Size		Core Size I.D.	Dispenser Weight	
		inch	mm		lbs	kg
DD-1A	024520	3/8 -1/2	9 -12	16"	48	22
DF-16A	422300	3/8 -1-1/4	9 - 32	16"	62	28
DF-1-12D	031318	3/8 -3/4	9 -19.0	16"	97	44
DF-X	429220	3/8 -1-1/4	9 - 32	16"	58	26

**DD-1A**  
Floor model with straproller. Can be suspended overhead.



**DF-16A**  
Designed for use with high-strength polyester strapping.



**DF-1-12D**  
For power equipment. Dancer arm and brake. Base sold separately (Part No. 024360).



**DF-X**  
An all purpose, easy loading dispenser for mill wound coils.



Offered by Signode Parts and Service only. Available at [www.signodeparts.com](http://www.signodeparts.com).

## Pneumatic tool accessories

See Page 14 for additional fittings.

A filter-regulator-lubricator (FRL) assembly is needed with all pneumatic tools and equipment. Additional pneumatic accessories are available from Signode to help provide optimum operation. Please contact your Signode sales representative for more information on the proper fittings for your specific tool or equipment.

Note: Only use light weight air tool oil in lubricator, such as Non-fluid Oil No. L0713-54 (Part No. 008556) or equivalent. (Part No. 429130 without hose)

Safety lockout valve



Regulator and filter

Lubricator